



POCKET-SIZE



www.montolit.com

5



8



17



20



22



24



26

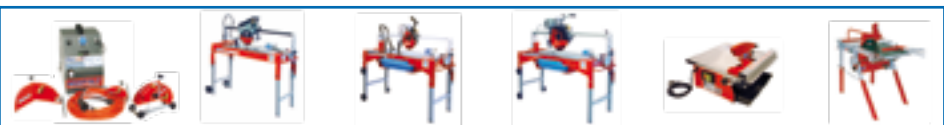

32



34

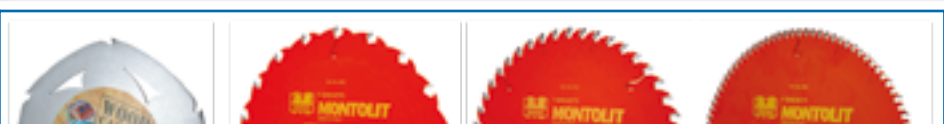

35

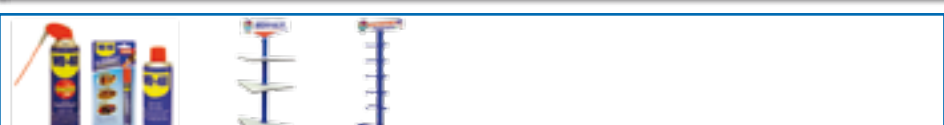

Popis a ilustrace jsou pouze indikativní. Výrobce se vyhrazuje právo provádět kdykoli a bez předchozího upozornění úpravy vlastních výrobků, které budou považovány za nezbytné za účelem zlepšení nebo pro jakékoli konstrukční či obchodní požadavky, za předpokladu, že budou zachovány základní charakteristiky zde uvedených a zřazovaných výrobků.



36



41



44



46



48



50



52



54





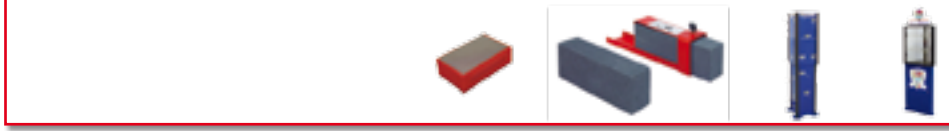





















58



61

Descriptions and illustrations are purely indicative. Without prejudice to the essential features of the models described and illustrated herein, the Company reserves all rights of marking product changes and without notice at any moment considered necessary for improvement of required in the interest of product engineering and sale.

	Maximální délka řezu <i>Maximum cutting length</i>		Použití za sucha <i>Dry use</i>
	Maximální tloušťka řezu <i>Maximum cutting thickness</i>		Použití za sucha není povoleno <i>Not permitted for dry cutting-off</i>
	Maximální povolený rozměr <i>Maximum dimensions</i>		Použití za mokra <i>Wet use</i>
	Délka diagonálního řezu <i>Diagonal cutting length</i>		Úhlová bruska <i>Electric angle grinder</i>
	Lámací síla <i>Power breaking</i>		Elektrická pila s vodním chlazením <i>Electric, water-cooled diamond tilesaw</i>
	Hmotnost <i>Weight</i>		Kotoučová pila <i>Slitting saw cut-off machine</i>
	Výkon motoru <i>Motor power</i>		Řezačka spar <i>Cutting-off machine</i>
	Maximální povolený průměr <i>Maximum diameter</i>		Řezačka dlažby <i>Floor cutting machine</i>
	Spoj frézy <i>Connection for cutter</i>		Ruční vrtačka <i>Power drill</i>
	Vnější a vnitřní průměr kotouče <i>Blade and central bore diameter</i>		Elektrická vrtačka s vodním chlazením <i>Water type electrical drilling machine</i>
	Počet segmentů <i>Number of segments</i>		Kotouč s patentovanou vyztuženou přírubou <i>Blade with armour plated flange - Pat.</i>
	Včetně kotouče <i>Blade included</i>		Ploché kotouč <i>Flat blade</i>
	Vrtání s přiklepem není povoleno <i>Not permitted for use with percussion drill</i>		



Art. 3

Art. 4H

ART.							
	cm	inch	cm	inch		t	kg
3	51	20	1 ÷ 16	3/8 ÷ 6 1/4	25	101	222
3STR	61	24	8,5 ÷ 23,5	3 1/4 ÷ 9 1/4	25	122	268
4H	41	16	2 ÷ 15,5	3/4 ÷ 6 1/8	10	55	121

OPTIONAL



Pomocný stolek
Support table
Art.190

Univerzální lamačka dlaždic Terrazzo/marble floor tile cutters



Art. 7

ART.						
	cm	inch	cm	inch	kg	lbs
5	31	12	0 ÷ 4	0 ÷ 1,5	20	44
7	41	16	0,5 ÷ 4,2	1/8 ÷ 1 5/8	30	66
9	51	20	1,2 ÷ 5,5	0,5 ÷ 2	43	95
11	61	24	1,5 ÷ 6,5	5/8 ÷ 2,5	61	134

Lamačka dlažby
Paving block cutters



Art. 6L



Art. 4



OPTIONAL*





Pomocný stolec
Support table
Art.190

ART.						
	cm	inch	cm	inch	kg	lbs
4	41	16	2 ÷ 15,5	¾ ÷ 6½	60	127
4KKS	41	16	10 ÷ 23	4 ÷ 9	67	147
6*	31	12	2 ÷ 15,5	¾ ÷ 6½	49	107
6R	31	12	0 ÷ 12,5	0 ÷ 5	45	98
6L	31	12	0 ÷ 10	0 ÷ 4	29	63
8	51	20	0 ÷ 10	0 ÷ 4	105	231
8K	62	24	3 ÷ 13	1¾ ÷ 5	118	259
8KS	62	24	13 ÷ 23	5 ÷ 9	122	268



Univerzální lamačka sádry
Universal plaster cutters



ART.							
	cm	inch	cm	inch	kg	lbs	
12	72	28 ⁵ / ₁₆	4 ÷ 14	1,5 ÷ 5,5	68	150	

Štípačka cihel
Brick cutters



ART.							
	cm	inch	cm	inch	kg	lbs	
14	17	6 ³ / ₄	3 ÷ 12,5	1 ³ / ₁₆ ÷ 5	15	33	

Štípačka střešní krytiny
Roof tile cutters



MINIMONTOLIT EVOLUTION 2

Řezačka dlažby

Tile cutters



Art. 26A2

ART.								
	cm	inch	cm	inch	cm	inch	kg	lbs
24	22	8	15 x 15	6 x 6	0 ÷ 1,5	0 ÷ 1/2	0,65	1,5
26A2	36	14	25 x 25	10 x 10	0 ÷ 2,0	0 ÷ 3/4	2,80	6,2
43A2	45	18	31 x 31	12 x 12	0 ÷ 2,0	0 ÷ 3/4	3,50	7,7

MASTERMONTLIT

Řezačka dlažby
Tile cutters



Art. 34



Art. 47M



ART.								
	cm	inch	cm	inch	cm	inch	kg	lbs
31	30	12	21 x 21	8 x 8	0 ÷ 2,5	0 ÷ 1	9,0	20,0
34	40	16	28 x 28	11 x 11	0 ÷ 2,5	0 ÷ 1	12,0	26,0
46	50	20	35 x 35	13,5 x 13,5	0 ÷ 2,5	0 ÷ 1	15,5	35,0
47M	62	24	44 x 44	18 x 18	0 ÷ 2,5	0 ÷ 1	16,5	36,0
92	92	36	65 x 65	25 x 25	0 ÷ 2,5	0 ÷ 1	29,0	75,0



MINIPIUMA

Řezačka dlažby
Tile cutters

OPTIONAL

Podložka na řezání mozaiky
Rubber mosaic pad

Art.58

14



Art. 26PBox

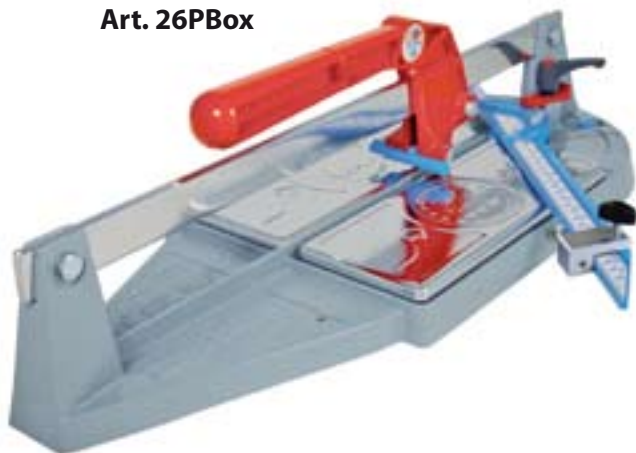

ART.								
	cm	inch	cm	inch	cm	inch	kg	lbs
26P	36	14	25 x 25	10 x 10	0 ÷ 2	0 ÷ 3/4	3,2	7,0
26PBox	36	14	25 x 25	10 x 10	0 ÷ 2	0 ÷ 3/4	5,8	12,8
43P	45	18	31 x 31	12 x 12	0 ÷ 2	0 ÷ 3/4	3,7	8,1
43PBox	45	18	31 x 31	12 x 12	0 ÷ 2	0 ÷ 3/4	6,3	13,8



OPTIONAL

Podložka na řezání mozaiky
Rubber mosaic pad
Art.58



14

MINIPIUMA

Řezačka dlažby
Tile cutters



Art. 26TBox



ART.								
	cm	inch	cm	inch	cm	inch	kg	lbs
26T	36	14	25 x 25	10 x 10	0 ÷ 2	0 ÷ 3/4	3,2	7,0
26TBox	36	14	25 x 25	10 x 10	0 ÷ 2	0 ÷ 3/4	5,8	12,8
43T	45	18	31 x 31	12 x 12	0 ÷ 2	0 ÷ 3/4	3,7	8,1
43TBox	45	18	31 x 31	12 x 12	0 ÷ 2	0 ÷ 3/4	6,3	13,8



MASTERPIUMA EVOLUTION 2

Řezačka dlažby
Tile cutters

OPTIONAL

Podložka na řezání mozaiky
Rubber mosaic pad
Art.58

14



Art. 125P2



Art. 52P2



ART.								
	cm	inch	cm	inch	cm	inch	kg	lbs
44P2	44	18	31 x 31	12 x 12	0 ÷ 2,5	0 ÷ 1	7,0	15,4
52P2	52	20	37 x 37	14 x 14	0 ÷ 2,5	0 ÷ 1	7,4	16,0
63P2	63	24	44 x 44	18 x 18	0 ÷ 2,5	0 ÷ 1	8,3	18,2
75P2	75	29	53 x 53	20 x 20	0 ÷ 2,5	0 ÷ 1	9,2	20,2
93P2	93	36	66 x 66	25 x 25	0 ÷ 2,5	0 ÷ 1	9,8	21,5
125P2	125	49	88 x 88	34,5 x 34,5	0 ÷ 2,5	0 ÷ 1	27,0	59,4



MASTERPIUMA EVOLUTION 2

Řezačka dlažby
Tile cutters



OPTIONAL

Podložka na řezání mozaiky
Rubber mosaic pad
Art.58



Art. 52T2



ART.								
	cm	inch	cm	inch	cm	inch	kg	lbs
44T2	44	18	31 x 31	12 x 12	0 ÷ 2	0 ÷ 3/4	6,8	15,0
52T2	52	20	37 x 37	14 x 14	0 ÷ 2	0 ÷ 3/4	7,2	15,8
63T2	63	24	44 x 44	18 x 18	0 ÷ 2	0 ÷ 3/4	8,1	17,8
75T2	75	29	53 x 53	20 x 20	0 ÷ 2	0 ÷ 3/4	9,0	19,8
93T2	93	36	66 x 66	25 x 25	0 ÷ 2	0 ÷ 3/4	9,6	21,0

MOSAKIT

Podložka na řezání mozaiky/křehkých dlaždic
Rubber pad for mosaic/soft ceramic tiles

Art. 58



Řezačka dlažby/mozaiky
Ceramic/mosaic tile cutters

OPTIONAL

Kleště na dlažbu/mozaiku
Tiles/mosaic nibbler



Art.40

Art. 38

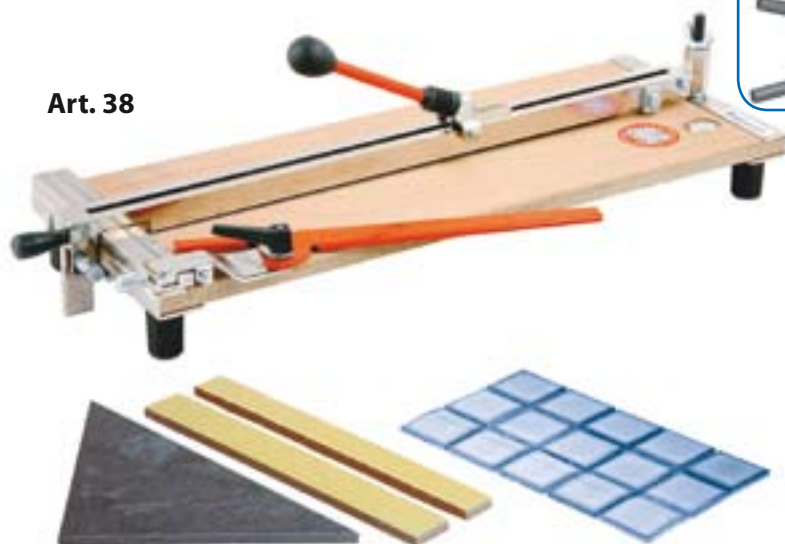

ART.								
	cm	inch	cm	inch	cm	inch	kg	lbs
36	37	14	26 x 26	10 x 10	0 ÷ 2	0 ÷ 3/4	7,4	16,2
38	53	21	37 x 37	14 x 14	0 ÷ 2	0 ÷ 3/4	8,8	19,3
41	63	24	44 x 44	18 x 18	0 ÷ 2	0 ÷ 3/4	9,0	19,8
44	91	36	64 x 64	25 x 25	0 ÷ 2	0 ÷ 3/4	12,0	26,4

Elektrická řezačka na dlažbu, obklady/mozaiku
Electric tile saw for tiles/mosaic



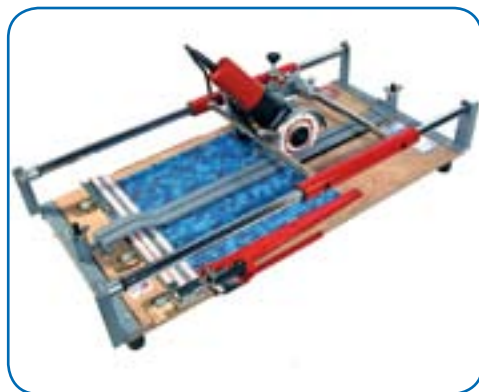

VČETNĚ

Ø 100 mm



DOPORUČENÉ DIAMANTOVÉ KOTOUČE
RECOMMENDED DIAMOND BLADES



ART.									
	V~	cm	inch	cm	inch	cm	inch	kg	lbs
51	230	51	20	36 x 36	14 x 14	0 ÷ 2	0 ÷ ¾	23,5	51,7
51B	115	51	20	36 x 36	14 x 14	0 ÷ 2	0 ÷ ¾	23,5	51,7



COMBI SLALOM

Řezačka obkladů a dlažby

Tile cutters for curve cut



ART.								
	cm	inch	cm	inch	cm	inch	kg	lbs
S63	63	24	44 x 44	18 x 18	0 ÷ 2	0 ÷ 3/4	19	42



COMBI SLALOM

Nastavitelná šablona
Variable template

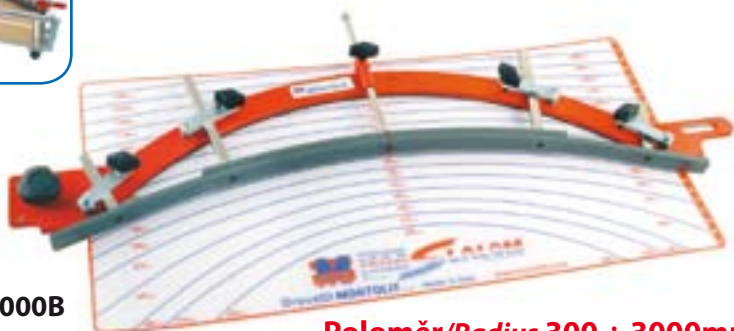

Art. SR000B

Poloměr/Radius 300 ÷ 3000mm

IDEAL BREAKING SYSTEM

Speciální lamač na předem naříznuté dlaždice
Special snapper for pre-scored tiles

Art. 57



KOPIA PROFILE



HOBBY BOX



Art. 26K

OBSAHUJE:

Řezačka dlažby a obkladů art. 26E • Náhradní řezací kolečko art. 243 • Štípací kleště art. 33 • Gumová špachtle • Ozubená špachtle • Přísavka • Pár nákoleníků • Mísidlo pro vrtačku • 2 sáčky distančních křížků.

Contents:

Tile cutter art. 26E • Spare wheel art. 243 • Nibbler art. 33 • Grout spreader • Notch trowel • Suction cup for D.I.Y. • Rubber knee pads • Paint and mud mixers • 2 Cross shape tile spacer.

ERGO SUPPORTER

Pracovní stůl pro obkladače
Work-table for tile-layer

Art. 996



TIRAMOLLA

Přísavka pro obkladače a dlaždiče
Sucker for tile-layer



Pokosníky
Universal folding squares



Art. 62



Art. 61



ART.	ℓ	
	mm	inch
61	250	10,0
62	400	16,0
63	600	23,5

CUT KIT

Víceúčelový nůž
Multipurpose cutter



Art. 25K



Art. 25V

Široké štípací kleště pro obkladače
Tile Nibbler with open cutting jaw

Art. 33



Štípací kleště Papoušek s nastavitelnými čelistmi
Tile Nibbler with adjustable cutting jaw

Art. 54



Speciální štípací kleště na velmi tvrdé materiály
Tile nibbler designed especially for extra hard tiles

Art. 55

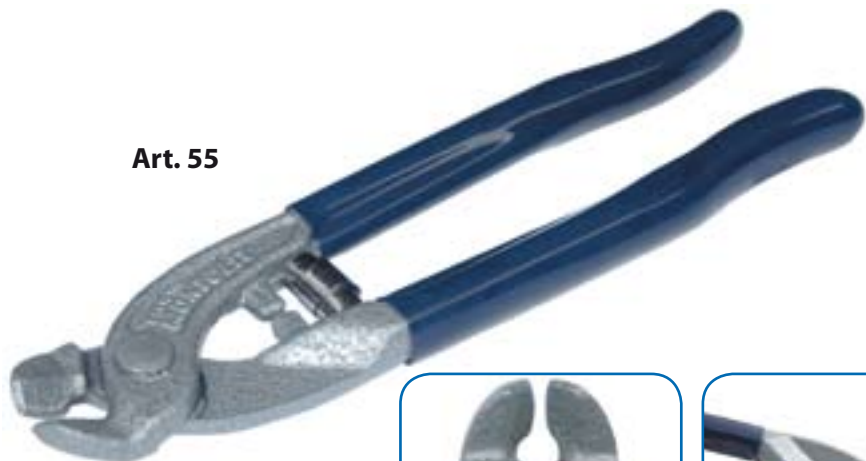

Štípací kleště na nejtvrďší glazované dlažby a mozaiku
Tile nibbler designed especially for extra hard/glazed tiles and mosaic

Art. 55W



LASER MEASURE

Laserový měřič
Laser meter



Art. 71ML

LASER SQUARE

Laserový úhломěr
2 Beam laser layout tool



NOVÝ

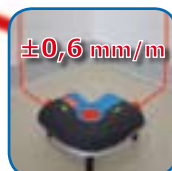
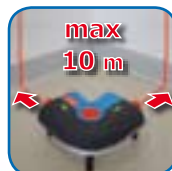

Art. 72TL



OUBIK LASER

Laserový samonivelační vytyčovač
Automatic laser level



Art. 70AL



STRAIT-LINE®

Laserový vytyčovač s 1 linií
1 Beam laser line generator



Art. 69TL

STRAIT-LINE®

Detektor výztuže
Stud finder



Art. 68RL

GUMMY

Gumová palička
Rubber mallet

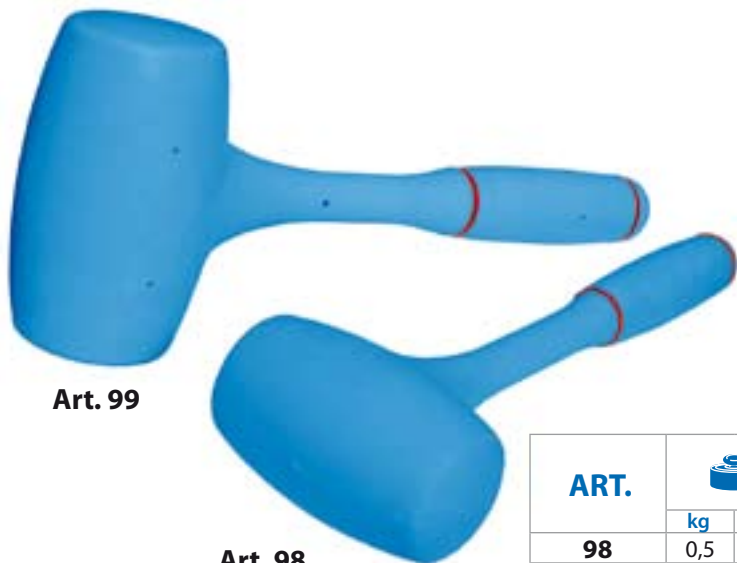

Art. 99

Art. 98

ART.			
	kg	lbs	
98	0,5	1,1	
99	1,0	2,2	

ENERGY

Palice pro obkladače, dlaždiče, zedníky
Sledge-hammer for tile-layer, stone floor-layer, brick-layer

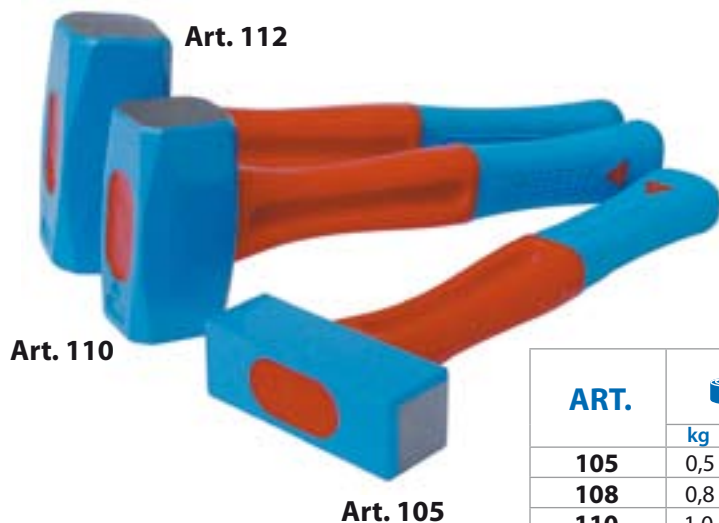

Art. 112

Art. 110

Art. 105

ART.			
	kg	lbs	
105	0,5	1,1	
108	0,8	1,7	
110	1,0	2,2	
112	1,2	2,6	

Páčidlo
Claw bar



Art. 59

Patentované tesařské kladivo
Patented claw hammer



ART.		
	kg	lbs
91	0,4	0,9

Palice na dlaždice / autoblok
Hammer for slab and keyblock material



ART.		
	kg	lbs
93	1,5	3,3
94	1,5	3,3

Art. 93

Art. 94

AQUAFLEX SYSTEM

Profesionální systém pro odstranění prachu při použití úhlových brusek
 Professional System for eliminating the dust using the angle-grinders







+ životnost + výkony
 vašeho diamantového nástroje
more life & more performances
 for your diamond blades



* Neobsahuje úhlovou brusku
 Grinding machine not included



 Art. EM115	ART.	Ø		 V~	 max W
		mm	inch		
	EM115	115	4,5	230	2.500
	EM125	125	5	230	2.500
	EM230	230	9	230	2.500
	EM2x180	180	7	230	2.500
 Art. AM2x180  Art. AM230	AM115	115	4,5		
	AM125	125	5		
	AM230	230	9		
	AM2x180	180	7		

BROOKLYN EVOLUTION

Elektrická pila s vodním chlazením
Electric, water-cooled diamond tile saws



OPTIONAL

Art.1049

Pomocný stolek
Support table

(x artt. 980EV/981EV/984EV/985EV)



Jolly

VČETNĚ DIAMANTOVÉHO KOTOUČE:
DIAMOND BLADE INCLUDED:



CPS

ART.											
	V~/kW	cm	inch	cm	inch	cm	inch	mm	kg	lbs	
980EV	230/0,9	88	34,5	62 x 62	24 x 24	0 ÷ 3,5	0 ÷ 1 ³ / ₈	180/25,4	48	106	
984EV	230/0,9	90	35,5	64 x 64	25 x 25	0 ÷ 4,5	0 ÷ 1 ³ / ₄	200/25,4	48	106	
981EV	115/0,9	88	34,5	62 x 62	24 x 24	0 ÷ 3,5	0 ÷ 1 ³ / ₈	180/25,4	48	106	
985EV	115/0,9	90	35,5	64 x 64	25 x 25	0 ÷ 4,5	0 ÷ 1 ³ / ₄	200/25,4	48	106	
986	230/0,9	126	49	89 x 89	35 x 35	0 ÷ 3,5	0 ÷ 1 ³ / ₈	180/25,4	68	150	
988	230/0,9	128	50	90,5 x 90,5	35,5 x 35,5	0 ÷ 4,5	0 ÷ 1 ³ / ₄	200/25,4	68	150	
987	115/0,9	126	49	89 x 89	35 x 35	0 ÷ 3,5	0 ÷ 1 ³ / ₈	180/25,4	68	150	
989	115/0,9	128	50	90,5 x 90,5	35,5 x 35,5	0 ÷ 4,5	0 ÷ 1 ³ / ₄	200/25,4	68	150	

TOP

VČETNĚ DIAMANTOVÉHO KOTOUČE:
DIAMOND BLADE INCLUDED:



SCX

984EVSCX	230/0,9	90	35,5	64 x 64	25 x 25	0 ÷ 4,5	0 ÷ 1 ³ / ₄	200/25,4	48	106	
985EVSCX	115/0,9	90	35,5	64 x 64	25 x 25	0 ÷ 4,5	0 ÷ 1 ³ / ₄	200/25,4	48	106	



MINIMASTER BROOKLYN EVOLUTION

Elektrická pila s vodním chlazením

Electric, water-cooled diamond tile saws



OPTIONAL



VČETNĚ DIAMANTOVÉHO KOTOUČE PODLE VLASTNÍ VOLBY:
DIAMOND BLADE INCLUDED AT YOUR CHOICE:



CPS



TBH

ART.										
	V~/kW	cm	inch	cm	inch	cm	inch	mm	kg	lbs
940EV	230/1,1	105	41	74 x 74	29 x 29	0 ÷ 7	0 ÷ 2¾	230/25,4	73	161
944EV	230/1,1	108	42	76 x 76	30 x 30	0 ÷ 8	0 ÷ 3⅛	250/25,4	73	161
941EV	115/1,1	105	41	74 x 74	29 x 29	0 ÷ 7	0 ÷ 2¾	230/25,4	73	161
945EV	115/1,1	108	42	76 x 76	30 X 30	0 ÷ 8	0 ÷ 3⅛	250/25,4	73	161

TOP

VČETNĚ DIAMANTOVÉHO KOTOUČE:
DIAMOND BLADE INCLUDED:



SCX

944EVSCX	230/1,1	108	42	76 x 76	30 x 30	0 ÷ 8	0 ÷ 3⅛	250/25,4	73	161
945EVSCX	115/1,1	108	42	76 x 76	30 X 30	0 ÷ 8	0 ÷ 3⅛	250/25,4	73	161



MASTER BROOKLYN EVOLUTION

Elektrická pila s vodním chlazením
Electric, water-cooled diamond tile saws



OPTIONAL

Art.1051
Pomocný stolek
Support table



STANDARD

VČETNĚ DIAMANTOVÉHO KOTOUČE PODLE VLASTNÍ VOLBY:
DIAMOND BLADE INCLUDED AT YOUR CHOICE:



ART.										
	V~/kW	cm	inch	cm	inch	cm	inch	mm	kg	lbs
990EV	230/2,2	120	47	85 x 85	33 x 33	0 ÷ 10,5	0 ÷ 4 1/8	300/25,4	97	213
991EV	230/2,2	125	49	88 x 88	34 x 34	0 ÷ 13	0 ÷ 5 1/8	350/25,4	97	213
954EV	115/1,5	120	47	85 x 85	33 x 33	0 ÷ 10,5	0 ÷ 4 1/8	300/25,4	97	213
955EV	115/1,5	125	49	88 x 88	34 X 34	0 ÷ 13	0 ÷ 5 1/8	350/25,4	97	213

TOP

VČETNĚ DIAMANTOVÉHO KOTOUČE PODLE VLASTNÍ VOLBY:
DIAMOND BLADE INCLUDED AT YOUR CHOICE:



ART.										
	V~/kW	cm	inch	cm	inch	cm	inch	mm	kg	lbs
992EV	230/2,2	120	47	85 x 85	33 x 33	0 ÷ 10,5	0 ÷ 4 1/8	300/25,4	97	213
993EV	230/2,2	125	49	88 x 88	34 x 34	0 ÷ 13	0 ÷ 5 1/8	350/25,4	97	213
956EV	115/1,5	120	47	85 x 85	33 x 33	0 ÷ 10,5	0 ÷ 4 1/8	300/25,4	97	213
957EV	115/1,5	125	49	88 x 88	34 X 34	0 ÷ 13	0 ÷ 5 1/8	350/25,4	97	213



MINIELETTROMONTOLIT

Elektrická pila s vodním chlazením

Electric, water-cooled diamond tile saws



VČETNĚ DIAMANTOVÉHO KOTOUČE:
DIAMOND BLADE INCLUDED:



CE

ART.									
	V~/kW	Neomezený Unlimited	cm	inch	cm	inch	mm	kg	lbs
905EV	230/0,55	Neomezený Unlimited	25 x 25	10 x 10	0 ÷ 3,5	0 ÷ 1 3/8	180/22,2	13	29

DOPORUČENÉ DIAMANTOVÉ KOTOUČE:
RECOMMENDED DIAMOND BLADES:



CE



CPS



TC

ELETTROMONTOLIT

Elektrická pila s vodním chlazením
Electric, water-cooled diamond tile saws



Art. 964









Jolly

VČETNĚ DIAMANTOVÉHO KOTOUČE:
DIAMOND BLADE INCLUDED:



CPS

ART.											
	V~/kW	cm	inch	cm	inch	cm	inch	mm	kg	lbs	
930	230/0,9	50	19,5	35 x 35	14 x 14	0 ÷ 5,5	0 ÷ 2 1/8	230/30	51	112	
964	230/2,0	64	25,0	45 x 45	18 x 18	0 ÷ 8	0 ÷ 3 1/8	300/30	76	167	
931	115/0,9	50	19,5	35 x 35	14 x 14	0 ÷ 5,5	0 ÷ 2 1/8	230/30	51	112	
965	115/2,0	64	25,0	45 x 45	18 x 18	0 ÷ 8	0 ÷ 3 1/8	300/30	76	167	

DOPORUČENÉ DIAMANTOVÉ KOTOUČE:
RECOMMENDED DIAMOND BLADES:



CPS



TC



TBH



BIMBO FORATUTTO

Elektrická vrtačka s vodním chlazením pro diamantové korunky a vrtáky
 Electric, water-cooled corebit drills







OPTIONAL



Art. 995
 Stojan
 Support



ART.								
	V~/kW		mm	inch	cm	inch	kg	lbs
915	230/0,4	M16	120	4,7	0 ÷ 4,5	0 ÷ 1¾	17	37,4
916	115/0,4	volitelné vybavení: W5/8"	120	4,7	0 ÷ 4,5	0 ÷ 1¾	17	37,4

* DIAMANTOVÉ NÁŘADÍ NENÍ ZAHRNUTO
 * DIAMOND CUTTERS NOT INCLUDED



57



Art. 18



Art. 20

ART.							
	cm	inch	mm	inch	kg	lbs	
18	30 x 30	12 x 12	20 ÷ 80	3/4 ÷ 3	2,5	5,5	
20	30 x 30	12 x 12	21-27-35-65	3/4-1 1/8 -1 3/8 -2,5	2,9	6,4	

Univerzální unášecí trn
Universal arbor

Unášecí trn se zatahovacím středícím hrotem
Arbor with central retractable bit



Art. 87

Ø 10mm

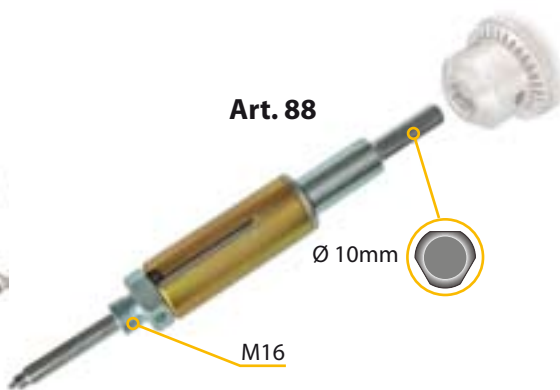

Art. 88

Ø 10mm

M16

ART.		
87	pro frézy Widia® a nářadí Widia® - SOFT TILES	
88	Diamantové nářadí FA (pagg. 56/57) - HARD TILES	

Pilové kotouče na dřevo
Circular blades for timber

ART.	Ø		
	mm	inch	



UPOZORNĚNÍ! Zkontrolovat v návodu pro použití a v bezpečnostních pokynech, zda je nástroj kompatibilní se strojem, na který bude namontován.

ATTENTION! Check that this blade is compatible with the machines to which it will be assembled consulting their instructions and safety handbooks.

115LL	115/22,2	4,5/7/8	6	
230LL	230/22,2	9/7/8	6	

S OMEZOVAČEM PILIN
WITH CHIP LIMITER



803	315/35-25,4	12,5/ 1 3/8-1	28	
804	350/35-25,4	14/ 1 3/8-1	24	
806	400/35-25,4	16/ 1 3/8-1	32	

UNIVERZÁLNÍ
UNIVERSAL



810	250/35-25,4	10/ 1 3/8-1	40	
812	300/35-25,4	12/ 1 3/8-1	48	
813	315/35-25,4	12,5/ 1 3/8-1	48	
814	350/35-25,4	14/ 1 3/8-1	54	
816	400/35-25,4	16/ 1 3/8-1	60	

UNIVERZÁLNÍ
UNIVERSAL



820	250/35-25,4	10/ 1 3/8-1	80	
822	300/35-25,4	12/ 1 3/8-1	96	

Protikorozní • Čistící • Odstraňuje vlhkost • Proniká • Lubrifikuje
Corrosion inhibitor • Cleaning agent • Water dispersant • Penetrant • Lubricant

ART.		
WD362	200ml - display 36 ks.	
WD124	400ml - box 12 ks.	
WD244	400ml - display 24 ks.	
WD500	500ml - display 24 ks.	
WD105	Nádoba 5 litrů	
WD125	Nádoba 25 litrů	
WD160	400 ml - expo 160 ks.	
WD240	200 ml - expo 240 ks.	
WDST12	Stick - display 12 ks.	
WDST24	Stick - pásky 24 ks.	



P R O M O T O

T O T E M

Modulární stojany
Assembling displays



Art. 950T
Expo Tools
 dim.: 125 x 68 x 210 cm

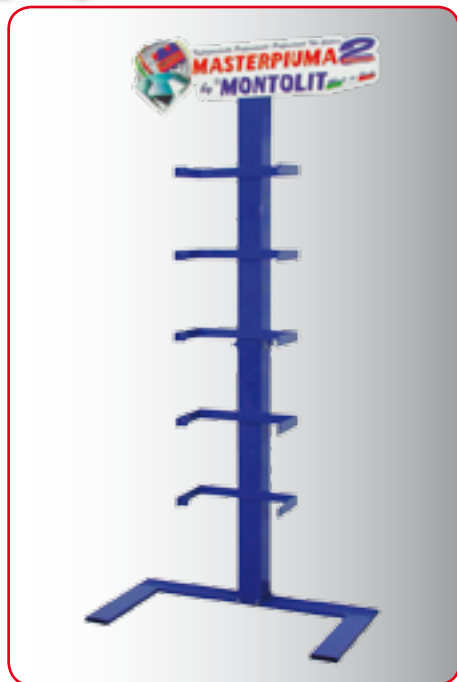

Art. 956M
Expo MASTERPIUMA
 dim.: 100 x 52 x 220 cm

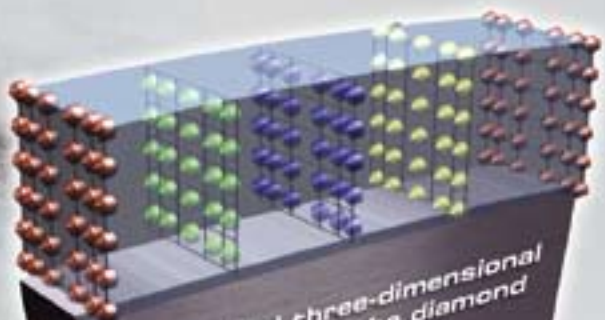

Controlled three-dimensional
distribution of the diamond

 **DNA**

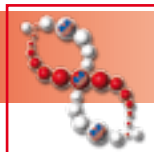



DNA

Diamantové kotouče "TURBO" Diamond blades "TURBO"

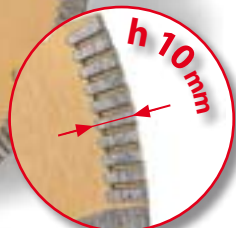
ZLATÁ ŘADA
VYSOKÁ TECHNOLOGIE



TX	Žula/Tvrký kámen/Beton/Stavební materiál Granite/Hard Stone/Concrete/Building Industry				
					
ART.	Ø		Ø		
	mm	inch	mm	inch	
TX115	115	4,5	22,2	7/8	
TX230	230	9	22,2	7/8	

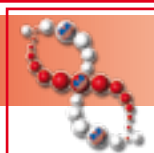



DNA

Segmentové diamantové kotouče "LASER" Diamond blades with segments "LASER"

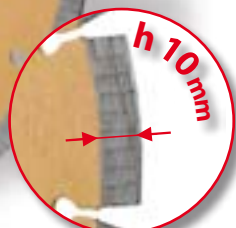
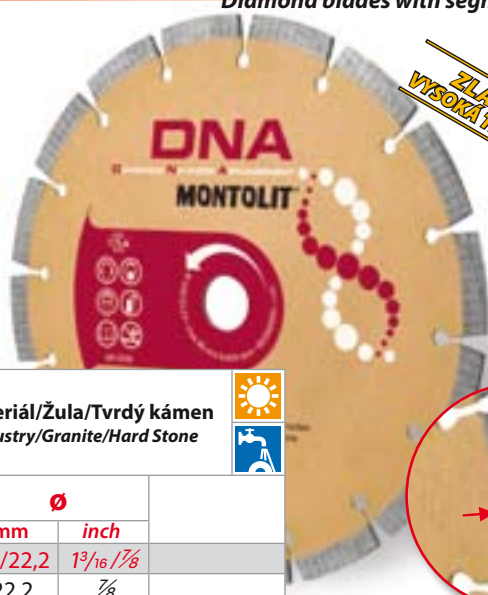
ZLATÁ ŘADA
VYSOKÁ TECHNOLOGIE



LX	Beton/Stavební materiál/Žula/Tvrký kámen Concrete/Building Industry/Granite/Hard Stone				
					
ART.	Ø		Ø		
	mm	inch	mm	inch	
LX180	180	7	30/22,2	1 ³ / ₁₆ 7/8	
LX230	230	9	22,2	7/8	





DNA

Segmentové diamantové kotouče "LASER"
Diamond blades with segments "LASER"



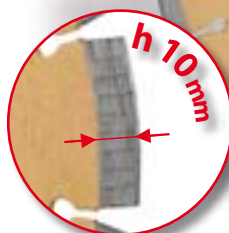
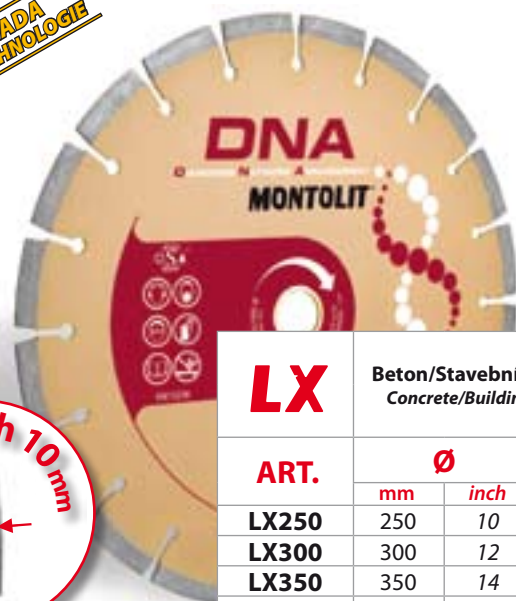

ZLATÁ ŘADA
VYSOKÁ TECHNOLOGIE

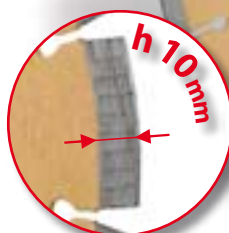
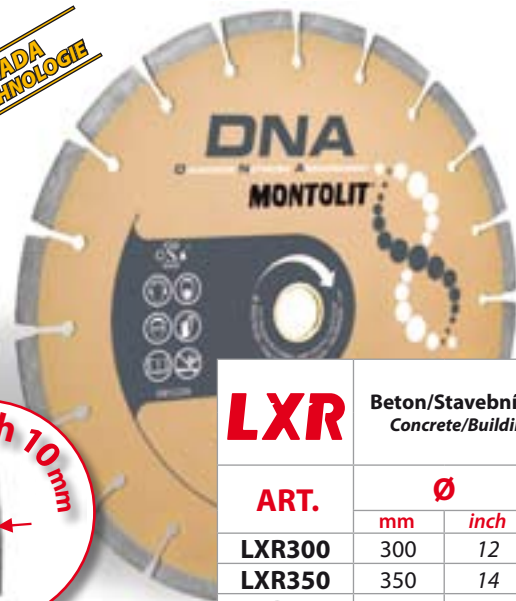

LX	Betón/Stavební materiál/Žula/Tvrký kámen Concrete/Building Industry/Granite/Hard Stone				 
	ART.	Ø		Ø	
	mm	inch	mm	inch	
LX250	250	10	30/25,4	1 ³ / ₁₆ /1	
LX300	300	12	30/25,4	1 ³ / ₁₆ /1	
LX350	350	14	30/25,4	1 ³ / ₁₆ /1	
LX400	400	16	30/25,4	1 ³ / ₁₆ /1	

ZLATÁ ŘADA
VYSOKÁ TECHNOLOGIE





LXR	Betón/Stavební materiál/Abrazivní materiál Concrete/Building Industry/Abrasive materials				 
	ART.	Ø		Ø	
	mm	inch	mm	inch	
LXR300	300	12	30/25,4	1 ³ / ₁₆ /1	
LXR350	350	14	30/25,4	1 ³ / ₁₆ /1	
LXR400	400	16	30/25,4	1 ³ / ₁₆ /1	





DNA

Segmentové diamantové kotouče Diamond blades with segments

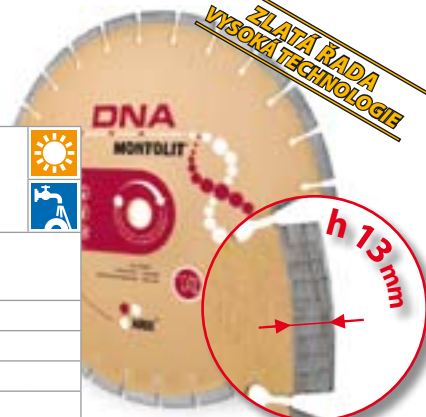

ZLATÁ ŘADA
VYSOKÁ TECHNOLOGIE

SX	Podlahy z vyzrálého betonu Concrete floor saw				 
	ART.	Ø		Ø	
		mm	inch	mm	inch
SX350		350	14	30/25,4	1 ³ / ₁₆ / 1
SX400		400	16	30/25,4	1 ³ / ₁₆ / 1
SX450		450	18	30/25,4	1 ³ / ₁₆ / 1
SX500		500	20	30/25,4	1 ³ / ₁₆ / 1

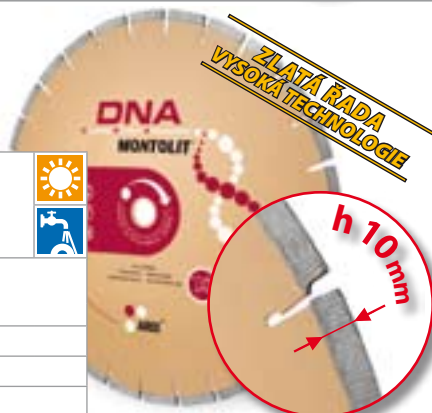

SXF	Podlahy z čerstvého betonu Green-mixed concrete floor saw				 
	ART.	Ø		Ø	
		mm	inch	mm	inch
SXF350		350	14	30/25,4	1 ³ / ₁₆ / 1
SXF400		400	16	30/25,4	1 ³ / ₁₆ / 1
SXF450		450	18	30/25,4	1 ³ / ₁₆ / 1



SXA	Asfalt Asphalt				 
	ART.	Ø		Ø	
		mm	inch	mm	inch
SXA400		400	16	30/25,4	1 ³ / ₁₆ / 1
SXA450		450	18	30/25,4	1 ³ / ₁₆ / 1
SXA500		500	20	30/25,4	1 ³ / ₁₆ / 1

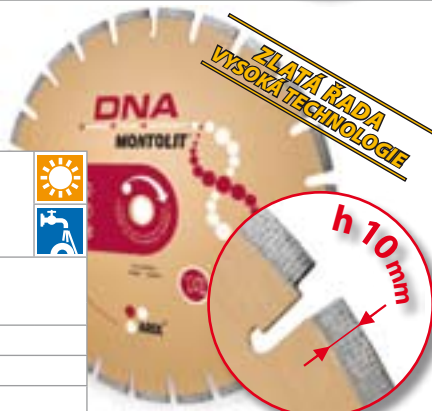

DNA

Segmentové diamantové kotouče
Diamond blades with segments



ZLATÁ ŘADA
VYSOKÁ TECHNOLOGIE

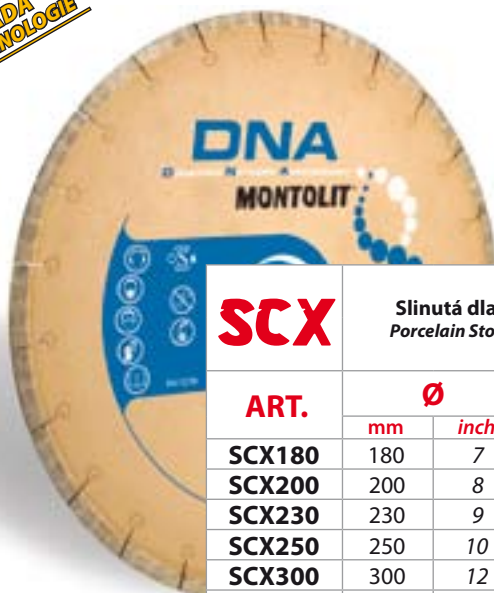

SCX

Slinutá dlažba/ Keramika "Pro"/Žula
Porcelain Stoneware/Ceramic "Pro"/Granite



ART.	Ø		Ø		
	mm	inch	mm	inch	
SCX180	180	7	30/25,4	1 ³ / ₁₆ /1	
SCX200	200	8	30/25,4	1 ³ / ₁₆ /1	
SCX230	230	9	30/25,4	1 ³ / ₁₆ /1	
SCX250	250	10	30/25,4	1 ³ / ₁₆ /1	
SCX300	300	12	30/25,4	1 ³ / ₁₆ /1	
SCX350	350	14	30/25,4	1 ³ / ₁₆ /1	

ZLATÁ ŘADA
VYSOKÁ TECHNOLOGIE

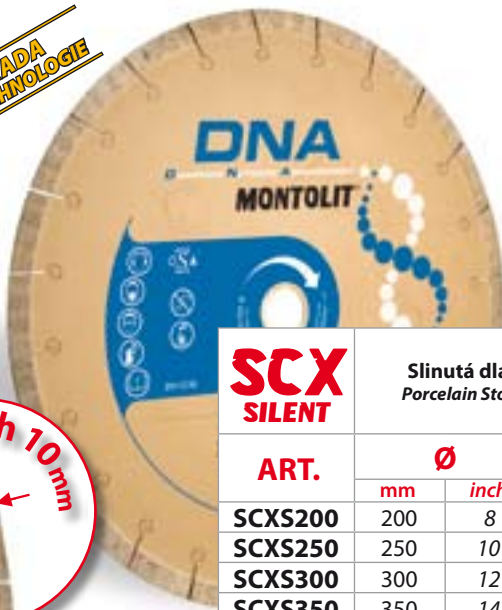

SCX SILENT

Slinutá dlažba/ Keramika "Pro"/Žula
Porcelain Stoneware/Ceramic "Pro"/Granite



ART.	Ø		Ø		
	mm	inch	mm	inch	
SCXS200	200	8	30/25,4	1 ³ / ₁₆ /1	
SCXS250	250	10	30/25,4	1 ³ / ₁₆ /1	
SCXS300	300	12	30/25,4	1 ³ / ₁₆ /1	
SCXS350	350	14	30/25,4	1 ³ / ₁₆ /1	

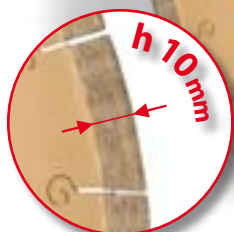





TURMONT

Diamantové kotouče "TURBO"
Diamond blades "TURBO"

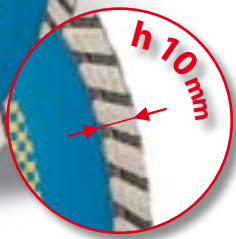
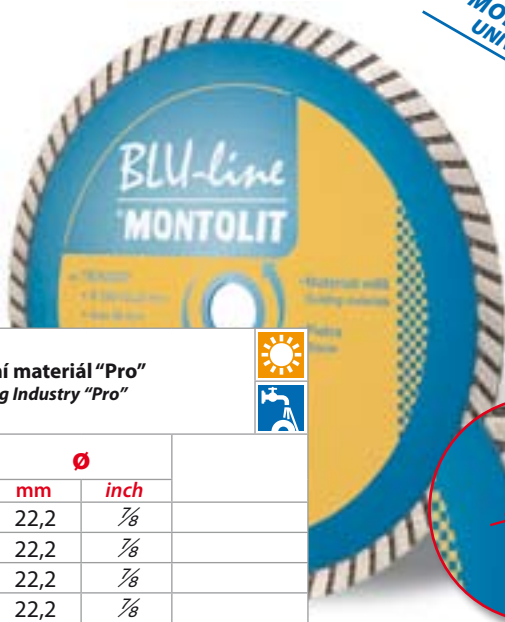

MODRÁ ŘADA
UNIVERZÁLNÍ



TEH	Stavební materiál "Pro" Building Industry "Pro"				 
	ART.	Ø		Ø	
	mm	inch	mm	inch	
TEH115	115	4,5	22,2	7/8	
TEH125	125	5	22,2	7/8	
TEH230P	230	9	22,2	7/8	
TEH230F	230	9	22,2	7/8	

MODRÁ ŘADA
UNIVERZÁLNÍ



TE	Stavební materiál "Pro" Building Industry "Pro"				 
	ART.	Ø		Ø	
	mm	inch	mm	inch	
TE300	300	12	30/25,4	1 ³ / ₁₆ / 1	
TE350	350	14	30/25,4	1 ³ / ₁₆ / 1	



TURMONT

Diamantové kotouče "TURBO"

Diamond blades "TURBO"



ČERVENÁ ŘADA
PROFESIONÁLNÍ

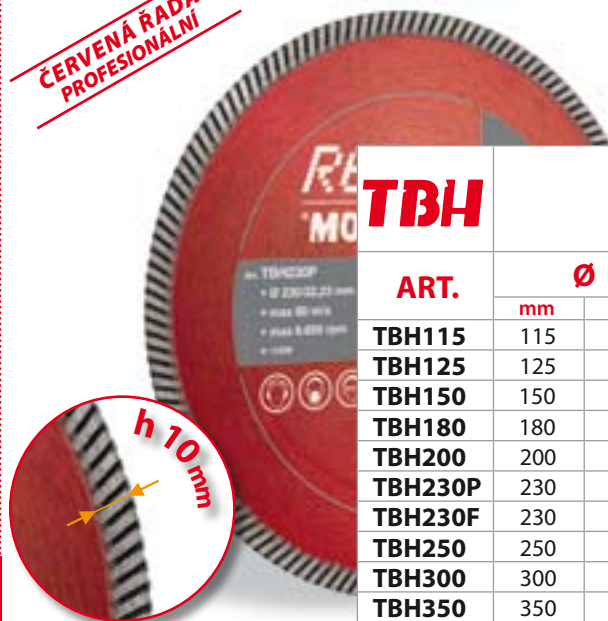

ART.	Beton / Žula Concrete/Granite			
	Ø		Ø	
	mm	inch	mm	inch
TBH115	115	4,5	22,2	7/8
TBH125	125	5	22,2	7/8
TBH150	150	6	22,2	7/8
TBH180	180	7	22,2	7/8
TBH200	200	8	30/25,4	1 ³ / ₁₆ /1
TBH230P	230	9	22,2	7/8
TBH230F	230	9	22,2	7/8
TBH250	250	10	30/25,4	1 ³ / ₁₆ /1
TBH300	300	12	30/25,4	1 ³ / ₁₆ /1
TBH350	350	14	30/25,4	1 ³ / ₁₆ /1



ČERVENÁ ŘADA
PROFESIONÁLNÍ

ART.	Armovaný beton/Abrazivní materiál/Tvrký kámen Reinforced Concrete/Abrasive Materials/Hard Stone			
	Ø		Ø	
	mm	inch	mm	inch
TV115R	115	4,5	22,2	7/8
TV230	230	9	22,2	7/8





TURMONT

Diamantové kotouče "TURBO"
Diamond blades "TURBO"



ČERVENÁ ŘADA
PROFESIONÁLNÍ

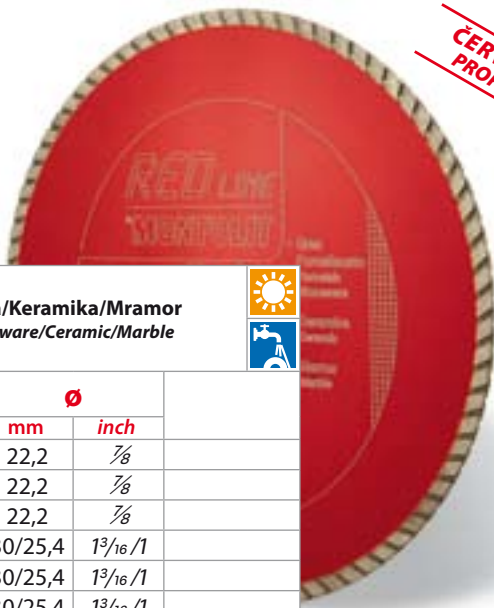

TCS TURBOBISTOURY	Slinutá dlažba/Tvrďá keramika Porcelain Stoneware/Hard Ceramic				
					
ART.	Ø		Ø		
	mm	inch	mm	inch	
TCS115R	115	4,5	22,2	7/8	
TCS125R	125	5	22,2	7/8	
TCS230F	230	9	22,2	7/8	

ČERVENÁ ŘADA
PROFESIONÁLNÍ



TC	Slinutá dlažba/Keramika/Mramor Porcelain Stoneware/Ceramic/Marble				
					
ART.	Ø		Ø		
	mm	inch	mm	inch	
TC125	125	5	22,2	7/8	
TC180	180	7	22,2	7/8	
TC200	200	8	22,2	7/8	
TC250	250	10	30/25,4	1 ³ / ₁₆ /1	
TC300	300	12	30/25,4	1 ³ / ₁₆ /1	
TC350	350	14	30/25,4	1 ³ / ₁₆ /1	

LASERMONT

Segmentové diamantové kotouče "LASER"
Diamond blades with segments "LASER"



MODRÁ ŘADA
UNIVERZÁLNÍ

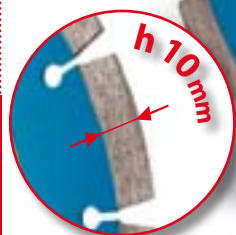

LEH

Stavební materiál
Building Industry



ART.	Ø		Ø	
	mm	inch	mm	inch
LEH115	115	4,5	22,2	7/8
LEH125	125	5	22,2	7/8
LEH230P	230	9	22,2	7/8
LEH230F	230	9	22,2	7/8
LEH30018	300	12	30/25,4	1 ³ / ₁₆ /1
LEH35021	350	14	30/25,4	1 ³ / ₁₆ /1
LEH40024	400	16	30/25,4	1 ³ / ₁₆ /1
LEH45026	450	18	30/25,4	1 ³ / ₁₆ /1

STŘÍBRNÁ ŘADA
"TOP"



LTF

BRACCIO DI FERRO

Silně armovaný beton/Tvrký kámen / Železo
Reinforced Concrete/Hard Stone/Iron



ART.	Ø		Ø	
	mm	inch	mm	inch
LTF230P	230	9	22,2	7/8
LTF230F	230	9	22,2	7/8

LASERMONT

Segmentové diamantové kotouče "LASER"
Diamond blades with segments "LASER"



ČERVENÁ ŘADA
PROFESIONÁLNÍ

LBH

Beton/Žula
Concrete/Granite



ART.	Ø		Ø	
	mm	inch	mm	inch
LBH115	115	4,5	22,2	7/8
LBH125	125	5	22,2	7/8
LBH150	150	6	30/22,2	1 3/16 / 7/8
LBH160	160	6 5/16	22,2	7/8
LBH180	180	7	30/22,2	1 3/16 / 7/8
LBH190	190	7,5	22,2	7/8
LBH200	200	8	30/25,4	1 3/16 / 1
LBH230P	230	9	22,2	7/8
LBH230F	230	9	22,2	7/8
LBH250	250	10	30/25,4	1 3/16 / 1
LBH30021	300	12	30/25,4	1 3/16 / 1
LBH35025	350	14	30/25,4	1 3/16 / 1
LBH40028	400	16	30/25,4	1 3/16 / 1
LBH45032	450	18	30/25,4	1 3/16 / 1

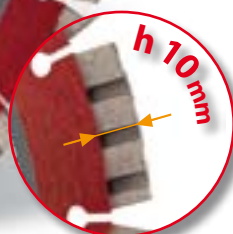

ČERVENÁ ŘADA
PROFESIONÁLNÍ

LA

Asfalt (pro malovýkonostní stroje)
Asphalt (For low power machines)



ART.	Ø		Ø	
	mm	inch	mm	inch
LA30018	300	12	30/25,4	1 3/16 / 1
LA35021	350	14	30/25,4	1 3/16 / 1
LA40024	400	16	30/25,4	1 3/16 / 1
LA45027	450	18	30/25,4	1 3/16 / 1



SECTORMONT

Segmentové diamantové kotouče
Diamond blades with segments



STŘÍBRNÁ ŘADA
"TOP"



h 10 mm



SF

Čerstvý beton
Green-Mixed Concrete



ART.	Ø		Ø	
	mm	inch	mm	inch
SF35025	350	14	30/25,4	1 ³ / ₁₆ /1
SF40028	400	16	30/25,4	1 ³ / ₁₆ /1
SF45032	450	18	30/25,4	1 ³ / ₁₆ /1

STŘÍBRNÁ ŘADA
"TOP"



SV

Vyzrálý beton
Old Concrete



ART.	Ø		Ø	
	mm	inch	mm	inch
SV30021	300	12	30/25,4	1 ³ / ₁₆ /1
SV35025	350	14	30/25,4	1 ³ / ₁₆ /1
SV40028	400	16	30/25,4	1 ³ / ₁₆ /1
SV45032	450	18	30/25,4	1 ³ / ₁₆ /1
SV50036*	500	20	30/25,4	1 ³ / ₁₆ /1
SV60042*	600	24	30/25,4	1 ³ / ₁₆ /1

*Na žádost - On request

ČERNÁ ŘADA
"TOP"



SA

Asfalt
Asphalt



ART.	Ø		Ø	
	mm	inch	mm	inch
SA30018	300	12	30/25,4	1 ³ / ₁₆ /1
SA35021	350	14	30/25,4	1 ³ / ₁₆ /1
SA40024	400	16	30/25,4	1 ³ / ₁₆ /1
SA45026	450	18	30/25,4	1 ³ / ₁₆ /1
SA50030*	500	20	30/25,4	1 ³ / ₁₆ /1
SA60036*	600	24	30/25,4	1 ³ / ₁₆ /1

*Na žádost - On request



SECTORMONT

Segmentové diamantové kotouče
Diamond blades with segments

SE	Stavební materiál/Žula Building Industry /Granite			
	Ø		Ø	
ART.	mm	inch	mm	inch
SE50030	500	20	30/25,4	1 ³ / ₁₆ /1
SE55032*	550	22	30/25,4	1 ³ / ₁₆ /1
SE60036*	600	24	30/25,4	1 ³ / ₁₆ /1
SE65038*	650	26	30/25,4	1 ³ / ₁₆ /1
SE70040*	700	28	30/25,4	1 ³ / ₁₆ /1



*Na žádost - On request

SR	Žáruvzdorný materiál/Abrazivní materiál/Žula Refractory/Abrasive Materials/Granite			
	Ø		Ø	
ART.	mm	inch	mm	inch
SR30021	300	12	30/25,4	1 ³ / ₁₆ /1
SR35025	350	14	30/25,4	1 ³ / ₁₆ /1
SR40028	400	16	30/25,4	1 ³ / ₁₆ /1
SR45032	450	18	30/25,4	1 ³ / ₁₆ /1
SR50030	500	20	30/25,4	1 ³ / ₁₆ /1
SR55032*	550	22	30/25,4	1 ³ / ₁₆ /1
SR60036	600	24	30/25,4	1 ³ / ₁₆ /1
SR65038*	650	26	30/25,4	1 ³ / ₁₆ /1



*Na žádost - On request

SM	Bílý a barevný mramor White and Coloured Marble			
	Ø		Ø	
ART.	mm	inch	mm	inch
SM30021	300	12	30/25,4	1 ³ / ₁₆ /1
SM35025	350	14	30/25,4	1 ³ / ₁₆ /1
SM40028	400	16	50/30	2/1 ³ / ₁₆
SM45032	450	18	50/30	2/1 ³ / ₁₆



SECTORMONT

Segmentové diamantové kotouče
Diamond blades with segments



STŘÍBRNÁ ŘADA
"TOP"

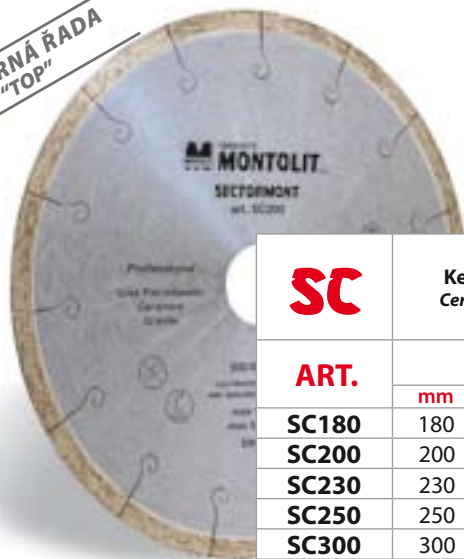

ART.	Ø		Ø		
	mm	inch	mm	inch	
SC180	180	7	25,4	1	
SC200	200	8	30/25,4	1 ³ / ₁₆ /1	
SC230	230	9	30/25,4	1 ³ / ₁₆ /1	
SC250	250	10	30/25,4	1 ³ / ₁₆ /1	
SC300	300	12	30/25,4	1 ³ / ₁₆ /1	
SC350	350	14	30/25,4	1 ³ / ₁₆ /1	

SC

Keramiká "Pro"/Slinutá dlažba / Žula
Ceramic "Pro"/Porcelain Stoneware/Granite



CERMONT

Diamantové celoobvodové kotouče
Continuous rim blades



ČERVENÁ ŘADA
PROFESIONÁLNÍ



ART.	Ø		Ø		
	mm	inch	mm	inch	
CE115	115	4,5	22,2	7/8	
CE125	125	5	22,2	7/8	
CE150	150	6	22,2	7/8	
CE180	180	7	25,4/22,2	1 ¹ / ₈	
CE200	200	8	30/25,4	1 ³ / ₁₆ /1	
CE230	230	9	30/25,4	1 ³ / ₁₆ /1	
CE250	250	10	30/25,4	1 ³ / ₁₆ /1	
CE300	300	12	30/25,4	1 ³ / ₁₆ /1	
CE350	350	14	30/25,4	1 ³ / ₁₆ /1	

CE

Keramiká/Slinutá dlažba/Mramor/Žula
Ceramic/Porcelain Stoneware/Marble/Granite





CERMONT

Diamantové celoobvodové kotouče
Continuous rim tile blades

ČERVENÁ ŘADA
PROFESIONÁLNÍ

ART.	Ø		Ø	
	mm	inch	mm	inch
CPS180	180	7	25,4/22,2	1 1/8
CPS200	200	8	30/25,4	1 3/16 / 1
CPS230	230	9	30/25,4	1 3/16 / 1
CPS250	250	10	30/25,4	1 3/16 / 1
CPS300	300	12	30/25,4	1 3/16 / 1
CPS350	350	14	30/25,4	1 3/16 / 1



Slinutá dlažba/Tvrdá keramika/Žula
Porcelain Stoneware/Hard Ceramic/Granite



ART.	Ø		Ø	
	mm	inch	mm	inch
CPF180	180	7	25,4/22,2	1 1/8
CPF200	200	8	30/25,4	1 3/16 / 1
CPF230	230	9	30/25,4	1 3/16 / 1
CPF250	250	10	30/25,4	1 3/16 / 1
CPF300	300	12	30/25,4	1 3/16 / 1
CPF350	350	14	30/25,4	1 3/16 / 1



Glazovaná a křehká keramika
Slinutá dlažba/Žula/Mramor
Soft Glazed Ceramic/Porcelain Stoneware/Granite/Marble

ČERVENÁ ŘADA
PROFESIONÁLNÍ



Kotouč s jemným zrněním
Maximální konečná úprava
Omezená rychlost
NETLAČIT PŘI REZÁNÍ!!!
Fine diamond grit blade
Clean cut - low speed
D'NT FORCE
WHILE CUTTING

ART.	Ø		Ø	
	mm	inch	mm	inch
CPV180	180	7	30/25,4	1 3/16 / 1
CPV200	200	8	30/25,4	1 3/16 / 1
CPV250	250	10	30/25,4	1 3/16 / 1
CPV300	300	12	30/25,4	1 3/16 / 1



Skleněné dlaždice
Glass tiles

STŘÍBRNÁ ŘADA
"TOP"



Kotouč s jemným zrněním
Maximální konečná úprava
Omezená rychlost
NETLAČIT PŘI REZÁNÍ!!!
Fine diamond grit blade
Clean cut - low speed
D'NT FORCE
WHILE CUTTING

CERMONT

Diamantové celobvodové kotouče
Continuous rim blades



**MODRÁ ŘADA
UNIVERZÁLNÍ**



ART.	Ø		Ø		
	mm	inch	mm	inch	
CSE115	115	4,5	22,2	7/8	
CSE230P	230	9	22,2	7/8	
CSE230F	230	9	22,2	7/8	

**ČERVENÁ ŘADA
PROFESIONÁLNÍ**



ART.	Ø		Ø		
	mm	inch	mm	inch	
CS115	115	4,5	22,2	7/8	

**ČERVENÁ ŘADA
PROFESIONÁLNÍ**

**NOVÝ
2010**

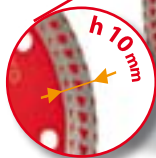

ART.	Ø		Ø		
	mm	inch	mm	inch	
CG115	115	4,5	22,2	7/8	

**STŘÍBRNÁ ŘADA
"TOP"**



ART.	Ø		Ø		
	mm	inch	mm	inch	
CT115	115	4,5	22,2	7/8	
CT125	125	5	22,2	7/8	
CT180	180	7	22,2	7/8	
CT230P	230	9	22,2	7/8	
CT230F	230	9	22,2	7/8	



CERMONT

Diamantové celoobvodové kotouče
Continuous rim tile blades

CM MOSAIC	Skleněná mozaika/přírodní kamenina Naturalstone and glass mosaic				
	ART.	Ø		Ø	
	mm	inch	mm	inch	
CM100	100	4	22,2	7/8	
CM115	115	4,5	22,2	7/8	
CM125	125	5	22,2	7/8	



Kotouč s jemným zrněním
Maximální konečná úprava
Omezená rychlost
NETLACIT PŘI REZÁNÍ!!!
Fine diamond grit blade
Clean cut - low speed
D'NT FORCE
WHILE CUTTING



DRAGSTER MOSAIC

"MONDRILLO TECH"

SSM	Mozaika Mosaic				
	ART.	Ø		Ø	
	mm	inch	mm	inch	
SSM100	100	4	22,2	7/8	
SSM115	115	4,5	22,2	7/8	



Kotouč s jemným zrněním
Maximální konečná úprava
Omezená rychlost
NETLACIT PŘI REZÁNÍ!!!
Fine diamond grit blade
Clean cut - low speed
D'NT FORCE
WHILE CUTTING



ELECTROPLATED

ED	Mramor/Skleněné vlákno Marble/Fiberglass				
	ART.	Ø		Ø	
	mm	inch	mm	inch	
ED115	115	4,5	22,2	7/8	
ED125	125	5	22,2	7/8	
ED180	180	7	22,2	7/8	
ED200	200	8	22,2	7/8	
ED230P	230	9	22,2	7/8	
ED230F	230	9	22,2	7/8	
ED250	250	10	30/25,4	1 ³ / ₁₆ / 1	
ED300	300	12	30/25,4	1 ³ / ₁₆ / 1	
ED350	350	14	30/25,4	1 ³ / ₁₆ / 1	



KILLER GRES

Diamantové korunky pro vrtání za sucha
Diamond core-bits for dry drilling

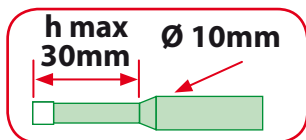

ART.	Ø		
	mm	inch	
FTJ05*	5	3/16	
FTJ06*	6	1/4	
FTJ08*	8	5/16	
FTJ10*	10	3/8	
FTJ12*	12	1/2	
FTJVA	Box + FTJ 05/06/08/10/12		

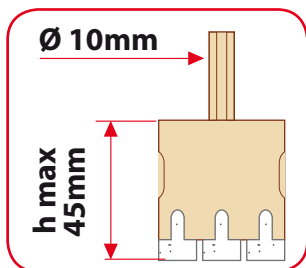
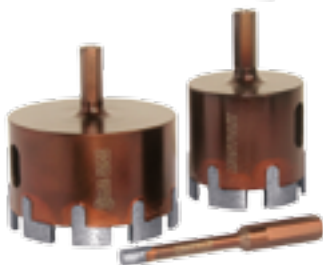

ART.	Ø		
	mm	inch	
FT 6*	6	1/4	
FT 8*	8	5/16	
FT 10*	10	3/8	
FT 15*	15	5/8	
FT 20	20	3/4	
FT 27	27	1 1/16	
FT 35	35	1 3/8	
FT 40	40	1 9/16	
FT 50	50	2	
FT 60	60	2 3/8	
FT 65	65	2,5	
FT 75	75	3	
FT100	100	4	
FT120	120	4 3/4	

* U průměru menších než 15mm, je pro optimální výkon nutné během vrtání vypnout vrtačku a korunku ochladit (viz fotografie).

* For obtaining the best output of the diamond core bits of diameter less than 15mm, switch off the electrical drill and water-cool the bit during the drill operation.





ART.	Ø	
	mm	inch
FS 6*	6	1/4
FS 8*	8	5/16
FS10*	10	3/8
FS12*	12	1/2
FS14*	14	9/16
FS16*	16	5/8
FS20	20	3/4
FS27	27	1 1/16
FS30	30	1 3/16
FS35	35	1 3/8
FS40	40	1 9/16
FS50	50	2
FS55	55	2 3/16
FS60	60	2 3/8
FS65	65	2,5
FS68	68	2 11/16
FS75	75	3
VFS60	Box + FS 27/35/50/60/75	
VFS65	Box + FS 27/35/50/65/75	
VFS01	Box	



FS Slinutá dlažba/Tvrká keramika/Žula/Mramor
Porcelain Stoneware/Hard Ceramic/Granite/Marble

Art. VFS65

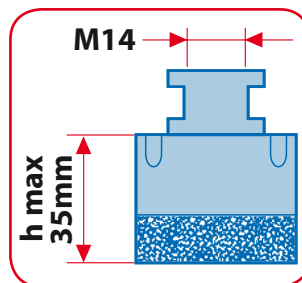

* U průměrů menších než 16mm, je pro optimální výkon nutné během vrtání vypnout vrtačku a korunku ochladit (viz fotografie).

* For obtaining the best output of the diamond core bits of diameter less than 14mm, switch off the grinder and water-cool the bit after having made every hole.



FORAFACILE

Profesionální sada na vrtání za mokra
Professional equipment for wet drilling



Art. CVG12



Art. MU

Art. FA

57

57



Art. VT120

Art. CVG12

Výplachová hlava s nádrží
Water feed complete with jerry

Ø 12mm

G 1/2"



Art. PS92

Držák na hroty pro MU (pro artt. 915/916/CVG12)
Drill-holder connector for MU (x artt. 915/916/CVG12)

W5/8"

G 1/2"

Ø 10mm



Art. 89

Adaptér M16 - G 1/2"
M16 - 1/2" gas adapter

M16

G 1/2"



Art. VT120

Přísavka pro vystředění
Sucker for holes centering





FORAFACILE

Profesionální sada na vrtání za mokra
Professional equipment for wet drilling



VAF

Slinutá dlažba/Keramika/Mramor/Žula
Porcelain Stoneware/Ceramic/Marble/Granite



ART.

VAF50

Box + CVG12 + 89 + PS92 + MU6 + MU8
+ VT120 + FA27 + FA35 + **FA50**

VAF60

Box + CVG12 + 89 + PS92 + MU6 + MU8
+ VT120 + FA27 + FA35 + **FA60**

VAF65

Box + CVG12 + 89 + PS92 + MU6 + MU8
+ VT120 + FA27 + FA35 + **FA65**



FORAKIT

Profesionální sada na vrtání za mokra
Professional equipment for wet drilling



Art. 88

Art. FA



Art.
VTKIT

Art. 88

Unášecí trn se zatahovacím středícím hrotem
Arbor with central retractable bit



BICCHIERONI

Art. VTKIT (Ø 40mm + Ø 60mm)

Příslavky pro mokré vrtání
Suckers for water drilling



VAK

Slinutá dlažba/Keramika/Mramor/Žula
Porcelain Stoneware/Ceramic/Marble/Granite



ART.

VAK50 Box + 88 + FA27 + FA35 + FA50

VAK60 Box + 88 + FA27 + FA35 + FA60

VAK65 Box + 88 + FA27 + FA35 + FA65



VAFA

Slinutá dlažba/Keramika/Mramor/Žula
Porcelain Stoneware/Ceramic/Marble/Granite



ART.

VAFA1 Box + 88 + FA20/27/30/35/40/45/50/65/75/100/120

VAF01 Box



Diamantové stopkové vrtáky s celoobvodovou korunkou Core drills and continuous crown diamond core-bits



Art. VAM14

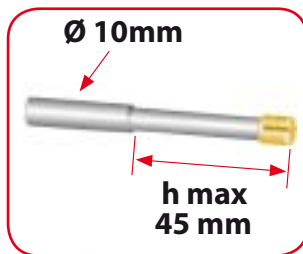

ART.	Ø	
	mm	inch
MU 5	5	$\frac{3}{16}$
MU 6	6	$\frac{1}{4}$
MU 8	8	$\frac{5}{16}$
MU10	10	$\frac{3}{8}$
MU12	12	$\frac{1}{2}$
MU14	14	$\frac{9}{16}$
VAM10	Box + MU6 + MU8 + MU10	
VAM14	Box + MU5 + MU6 + MU8 + MU10 + MU12 + MU14	

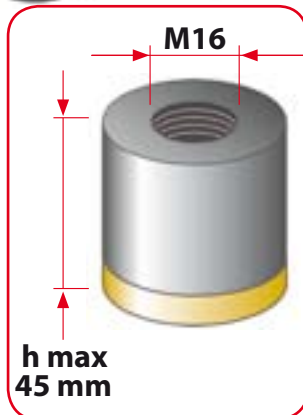

ART.	Ø	
	mm	inch
FA 20	20	$\frac{3}{4}$
FA 27	27	$1 \frac{1}{16}$
FA 30	30	$1 \frac{3}{16}$
FA 32	32	$1 \frac{2}{8}$
FA 35	35	$1 \frac{3}{8}$
FA 40	40	$1 \frac{9}{16}$
FA 45	45	$1 \frac{3}{4}$
FA 50	50	2
FA 55	55	$2 \frac{3}{16}$
FA 60	60	$2 \frac{3}{8}$
FA 65	65	2,5
FA 70	70	$2 \frac{3}{4}$
FA 75	75	3
FA100	100	4
FA120	120	$4 \frac{3}{4}$

MONDRILLO

Diamantové frézy na opracování hran
Diamond bevel profiles

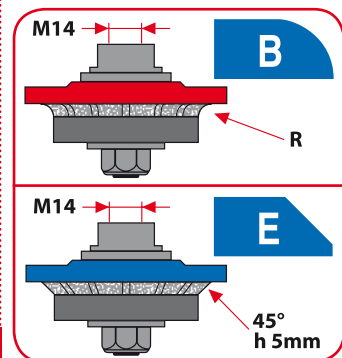

Slinutá dlažba/Žula/Mramor Porcelain Stoneware/Granite/Marble			
ART.			
VFPB05	"B" Profil - R = 5mm		
VFPB10	"B" Profil - R = 10mm		
VFPE05	"E" Profil - 45°		

MONDRILLO

Víceúčelový diamantový brusný kotouč
Diamond multipurpose grinding wheels





JEMNÝ		Slinutá dlažba/Keramika/Mramor Porcelain Stoneware/Ceramic/Marble					
		Ø		Ø			
ART.	mm	inch	mm	inch			
PE115GF	115	4,5	22,2	7/8			



STŘEDNÍ		Slinutá dlažba/Žula/Kámen/Beton/Cihly Porcelain Stoneware/Granite/Stone/Concrete/Bricks					
		Ø		Ø			
ART.	mm	inch	mm	inch			
PE115GG	115	4,5	22,2	7/8			





Brusný kotouč na broušení za sucha a za mokra Grinding cup wheels for dry and wet use

PUT	TURBO Žula/Beton Granite/Concrete		 
	ART.	\varnothing	
	mm	inch	
PUT115	115	4,5	Ø 22,2mm
PUT125	125	5	Ø 22,2mm





PUSC	SECTOR Beton/Kamenné materiály Concrete/Stone Materials		 
	ART.	\varnothing	
	mm	inch	
PUSC115	115	4,5	Ø 22,2mm
PUSC125	125	5	Ø 22,2mm





PUSA	SECTOR Abrazivní materiál Abrasive Materials		 
	ART.	\varnothing	
	mm	inch	
PUSA115	115	4,5	Ø 22,2mm
PUSA125	125	5	Ø 22,2mm



PU PRO	TURBO Stavební materiál / Žula Building Industry/Granite		 
	ART.	\varnothing	
	mm	inch	
PU100	100	4	A1: Ø 22,2mm
PU125	125	5	A2: M14
PU150	150	6	A4: W5/8"



PP PRO	CELOOBVODOVÝ · CONTINUOUS RIM Žula · Granite		 
	ART.	\varnothing	
	mm	inch	
PP100	100	4	A1: Ø 22,2mm A2: M14 A4: W5/8"



Segmentové diamantové vrtáky

Segmented diamond core-drills

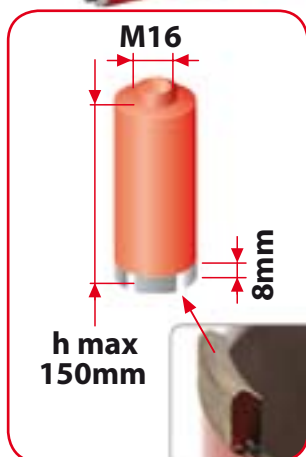

ART.	Ø		n°	
	mm	inch		
FU 36	36	1 7/16	3	
FU 42	42	1 5/8	3	
FU 52	52	2 1/16	3	
FU 57	57	2 1/4	3	
FU 62	62	2 11/16	3	
FU 68	68	2 11/16	4	
FU 82	82	3 1/4	4	
FU102	102	4 1/32	5	
FU112	112	4 3/8	5	
FU127	127	5	6	
FU132	132	5 3/16	6	
FU152	152	6	7	
FU162	162	6 3/8	8	
FU182	182	7 3/16	8	
FU200	200	7 7/8	9	

Beton/Cihly/Abrazivní cihly/Autoblok
Concrete/Bricks/Abrasive Bricks and Self-blocking



PŘÍSLUŠENSTVÍ

FITTINGS

ART.	ℓ		
	mm	inch	

G 1/2"  M16

AM16F

G 1/2"  M16

AM16M

Ø 12mm 

 M16

AU100 100 4
AU220 200 8

SDS PLUS 

 M16

AS110 110 4 5/16
AS230 220 9

SDS MAX 

 M16

ASMAX 170 6 3/4

M16 

PR300 300 12

Ø 9mm 

PC250 220 8 5/8

STŘEDNÍ



Art. 395

Čistící a oštrící brusy na diamantové nářadí
Grindstone for dressing diamond tools

Art. 394



NOVÝ

Art. 395BJ



Art. 394B

Art. 395B

JEMNÝ

Nejvyšší
Kvalita

MASTER TECH

Diamantové houbičky na zabrušování a konečnou úpravu jakéhokoli typu mramoru, žuly, slinuté dlažby a keramiky
Diamond hand pads for smoothing the edges of any type of marble, granite, porcelain stoneware and ceramics

Art. DT262



Art. DT606



DT060 - STŘEDNÍ
Gres, Slinutá dlažba,
kabřinec, žula.



DT200 - JEMNÝ
Jednožárová dlažba, dvoužárová
dlažba, pálená dlažba, mramor, sklo.

ART.		
DT262	Blistr: 1 art. DT060 + 1 art. DT200	
DT606	Box: 6 artt. DT060 - STŘEDNÍ	
DT620	Box: 6 artt. DT200 - JEMNÝ	

Stojan na diamantové kotouče
Displays for diamond blades

000010
TOTEM



Art. 955T
Expo diamond blades
dim.: 70 x 46 x 194 cm



Art. 958V
Crystal Display/Box
dim.: 70 x 40 x 190 cm





® BREVETTI

MONTOLIT S.p.A.

Via Turconi, 25 - 21050 Cantello (VA) Italy

Tel.: ++39 0332 419 211

++39 0332 417 744

Fax: ++39 0332 418 444

home page: www.montolit.com

e-mail: info@montolit.com